

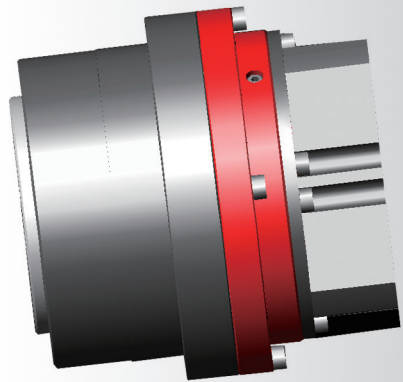

Xcellent Planetary XP(XF) series



Price Performer

***Universal Installation
Full Protection IP65
Extremely Compact
High Tilting Rigidity
Extremely Silent
High Dynamics
Simple To Use
XP(XF)***

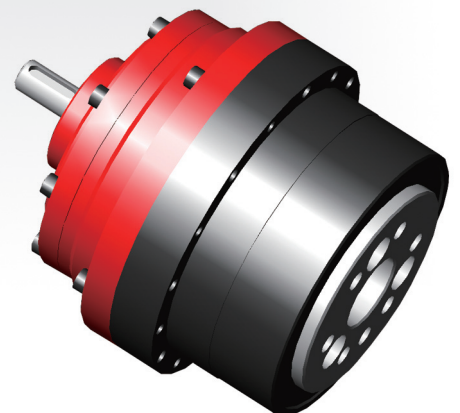
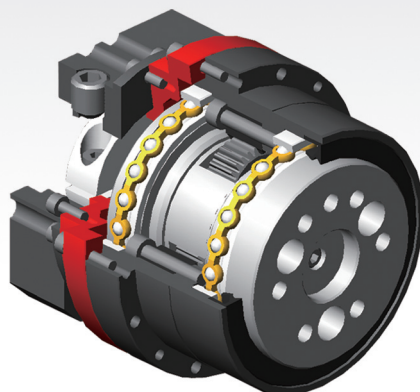
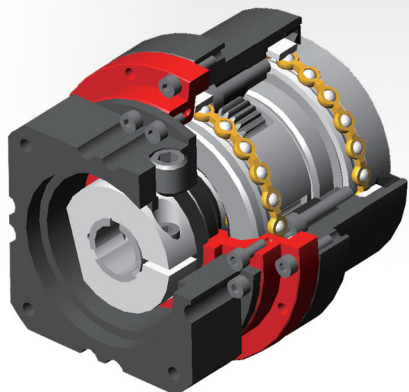
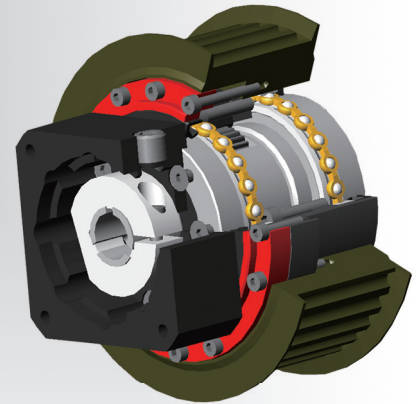
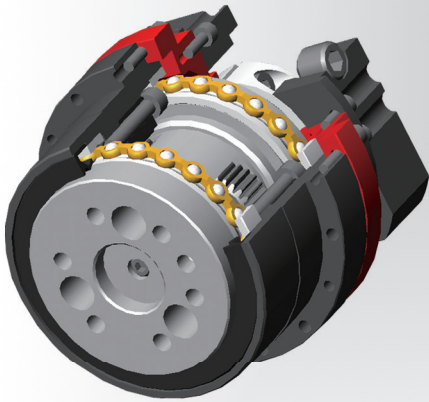
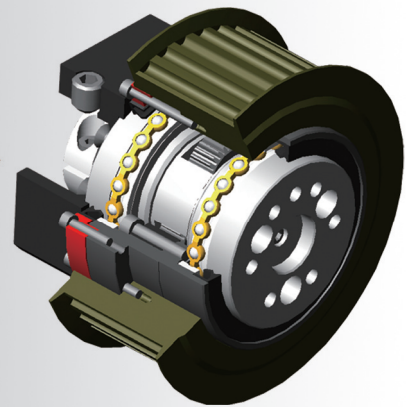

XP(XF) 规格一览表 Xcellent Planetary (XF) series Ratings at a glance

技术说明 Specifications	符号 Symbol	单位 Unit	XP 速比 ⁷⁾ XP Ratio ⁷⁾		型号 Model										
					XP(F)07A		XP(F)015		XP(F)045		XP(F)090		XP(F)180		
			1级	2级	1级	2级	1级	2级	1级	2级	1级	2级	1级	2级	
额定输出扭矩 Rated output torque (最大输出扭矩 当ED>60%或负载运行时间>20分钟/ Maximum output torque when ED>60%, or load cycle duration > 20 minutes)	T _{2n}	Nm	4	16, 20, 28 [*]	4	6.4	15	22	45	55	90	110	180	290	
			5	21, 25, 35 [*]	4.2	7.1	16	24	45	59	110	120	195	300	
			7	31, 43, 49, 61	4.5	6	17	28	43	64	90	140	207	300	
			10	(64), 91, 100 [*]	3.5	4	14	16	35	40	80	90	160	165	
最大加/减速扭矩 ¹⁾ Maximum Acceleration/Deceleration torque ¹⁾	T _{2B}	Nm	4	16, 20, 28 [*]	8	10	28	44	88	110	180	220	340	410	
			5	21, 25, 35 [*]	8.4	12	32	48	90	118	210	240	340	410	
			7	31, 43, 49, 61	8	10	28	50	86	120	160	280	340	410	
			10	(64), 91, 100 [*]	7	8	25	29	70	80	160	180	290	300	
峰值输出扭矩 (紧急刹车) ²⁾ Peak torque (Emergency stop) ²⁾	T _{2not}	Nm	4	16, 20, 28 [*]	16	17	42	66	129	165	240	330	480	520	
			5	21, 25, 35 [*]	16	17	48	72	135	176	300	360	480	520	
			7	31, 43, 49, 61	14	15	45	75	129	180	270	420	480	520	
			10	(64), 91, 100 [*]	12	12	36	42	102	120	180	270	350	400	
额定(连续的)输入转速 Rated (Cont.) Input Speed	n _{1n}	rpm	所有速比 All ratio		3000		3000		3000		3000		3000		
最高输入转速 Maximum input speed	n _{1max}	rpm			6000		6000		5000		5000		4000		
标准级 旋转空回 Standard torsional play XP	B	arcmin	1级 (1stage)	2级 (2stage)	16	20	12	15	10	14	10	14	10	14	
9					12	7	9	6	8	6	8	6	8		
6			8	5	6	4	6	4	6	4	6	4	6		
3			4	2	3	2	3	2	3	2	3	2	3		
抗扭转刚度 Torsional Stiffness	C _t	Nm/arcmin	4	16, 20, 28 [*]	0.5		2.4		7.1		17.2		33		
			5	21, 25, 35 [*]	0.5		2.4		7.1		17.2		33		
			7	31, 43, 49, 61	0.4		2.2		6		14		27		
			10	(64), 91, 100 [*]	0.4		2		5		10		22		
输入端转动惯量 ³⁾ Mass Moment of Inertia ³⁾	J _i	kg.cm ²	4	16	0.06	0.06	0.32	0.06	1.44	0.31	2.97	1.36	3.62	2.68	
			5	20, 21, 25, 31	0.06	0.06	0.31	0.06	1.36	0.31	2.68	1.36	2.94	2.68	
			7	28, 35, 43, 49, 64	0.06	0.06	0.3	0.06	1.30	0.3	2.48	1.30	2.94	2.48	
			10	61, 91, 100 [*]	0.06	0.06	0.3	0.06	1.27	0.3	2.39	1.27	2.68	2.39	
抗倾覆强度 Tilting rigidity	M _R	Nm/arcmin	所有速比 All ratio		11		19		51		127		229		

规格 Specifications	符号 Symbol	单位 Unit	平均输出转速 (rpm) Average output speed	型号 Model										
				XP(F)07A	XP(F)015	XP(F)045	XP(F)090	XP(F)180						
倾覆力矩 ⁴⁾ Tilting Moment Load⁴⁾	M _T	Nm	500	14	19	40	60	93						
			400	17	24	52	86	138						
			300	21	31	68	122	200						
			200	28	41	94	179	300						
			100	33	57	147	296	503						
轴向负载 ⁵⁾ Axial Load⁵⁾	F _A	N	500	125	139	217	238	256						
			400	150	172	280	340	379						
			300	186	219	368	483	551						
			200	243	293	508	709	823						
			100	359	445	795	1175	1383						
径向负载 ⁶⁾ Radial Load⁶⁾	F _R	N	500	565	644	1081	1325	1590						
			400	686	813	1405	1900	2359						
			300	848	1050	1837	2696	3419						
			200	1131	1389	2540	3955	5128						
			100	1333	1932	3972	6541	8598						
径向负载距离 Radial Load Distance	r _d	mm		24.75	29.5	37	45.25	58.5						
重量 (连带电机法兰) Weight (with motor flange)	m	kg	1级(stage) 2级(stage)	0.8 1	1.5 1.8	3.5 3.8	7.6 8.4	16 17						
运作噪音 Operating noise @n_{1n}=3000rpm	O _n	dB		< 68	< 66	< 68	< 70	< 70						
额定负载时工作效率 Efficiency with Rated Load	η	%		> 92	> 94	> 93	> 93	> 93						
使用寿命 Lifetime	L _h	hr		L ₁₀ > 10000 (L ₅₀ > 50000)										
润滑设计 Lubrication	永久性润滑, 封闭式系统 Lifetime Lubrication, Closed system													
表面防护 Surface Protection	阳极化处理, 输入输出端除外 Anodized aluminum, except input & output													
安装定位 Installation Position	任意方向, 自由定位 Any, include variable orientation													
使用温度 Operating Temperature	-10 °C ~ +90 °C (可特选 -30 °C ~ +90 °C On request)													
输出转向 Output direction of Rotation	与输入端一致 The same as input													
防护规格 Degree of Protection	IP65													

CP

XP

MM

SS

XQ

- 1) 在最高每小时1000运转次数时, 加/减速度占运行周期比例小于5%, 同时发生在 0.3秒以内。
At a maximum 1000cycle per hour, percentage of acc. & dec. time in one cycle less than 5%, and duration of the impulse less than 0.3 sec.
- 2) 在XP系列的使用寿命中产生紧急停止次数不可多于1000次。Max 1000 times during XP series lifetime.
- 3) 随应用电机输入轴径而异。Depends on applied motor shaft diameter.
- 4) 不带径向负载时的最高值。(请参考主轴轴承负荷图。) Maximum value without axial load. Refer main bearing load diagram.
- 5) 从输出轴心计算起的最高值, 不带倾覆力矩计算下。(请参考主轴轴承负荷图。) Maximum value at the center of output rotation, without tilting moment load. Refer main bearing load diagram.
- 6) 以径向负载距离为基准的最高值, 不带轴向负载计算下。(请参考各个型号尺寸。) Maximum value at the radial load distance, without axial load. Refer each series dimensions.
- 7) XF系列速比= XP 的速比 减去 1。*所示XP07A 2级速比。(请参第14页 XP(XF)订购须知信息中每个型号的可用速比。)
[XF series ratio is 'XP ratio-1'. * is XP07A 2 stage ratio. Please refer page 14 XP ordering information for each model available ratios.]

XP(XF) 主轴承载图 XP(XF) series Main bearing load diagram

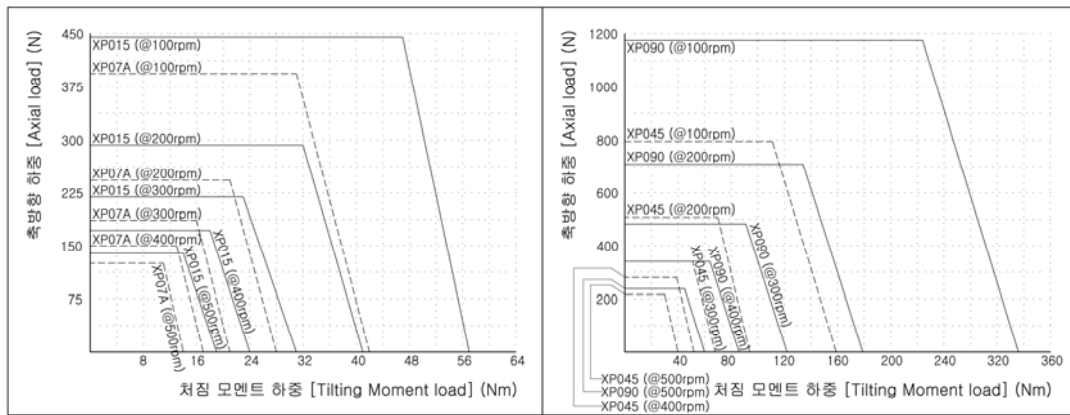

当轴向载荷与倾覆力矩同时作用在输出法兰时，请参考XP(XF)系列主轴承载图表。Please refer XP (XF) series main bearing load diagram, when axial and tilting loads are applied together on XP (XF) output flange.

XP(XF)系列 额定输出扭矩因数图表 XP(XF) series Rated Output Torque factor diagram

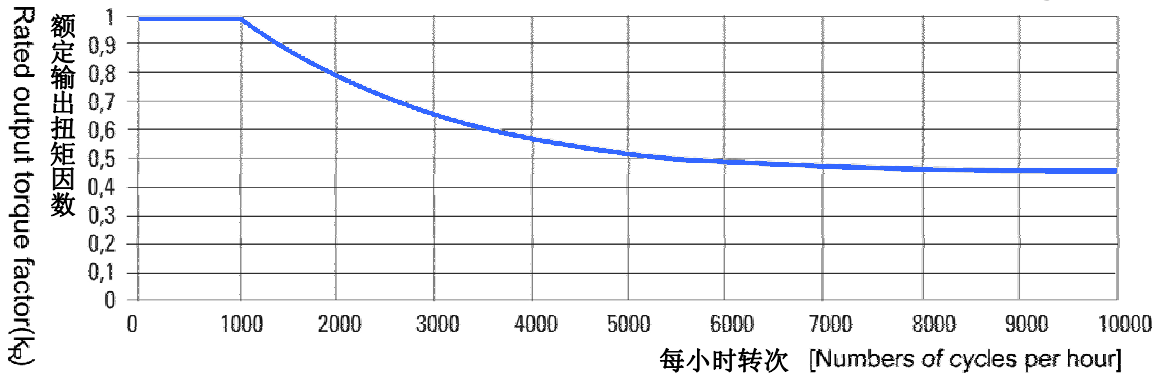

当每小时运转次数超过 1000 次时，请参考以上 XP(XF)系列的额定输出扭矩因数图表，以计算设计输出扭矩。

Please refer XP(XF) series rated output torque diagram for application that numbers of cycles per hour are over 1000 times.

举例：当每小时运转次数=1800次，根据图表所示，因数=0.8；因此，齿轮箱为要保持正常使用寿命的前提下所依据的设计输出扭矩=额定输出扭矩x 0.8

Example: If numbers of cycles per hour are 1800 times, then only approximately 0.8 times of each XP(XF) model rated output torque should be applied to satisfy lifetime.

XP(XF)系列 加/减速扭矩因数图表 XP(XF) series acc./dec. torque factor diagram

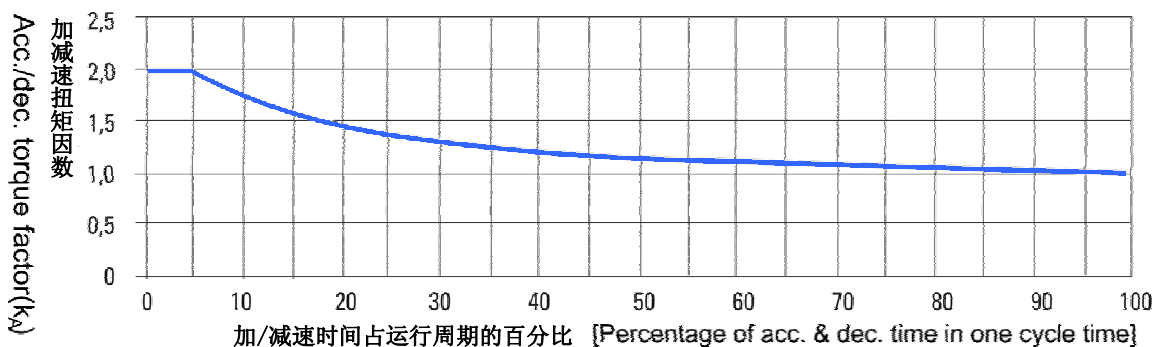

以上图表显示个别XP 系列的最高加/减速扭矩的计算因数。条件：每小时低于1000 运转次数，每次运转加/减速占时比例不大于总耗时的5%，并且不超过0.3 秒。 It shows maximum Acceleration/deceleration torque as a numbers of times of each XP model rated output torque, under the condition of max. 1000 cycle per hour, percentage of acceleration & deceleration time in one cycle less than 5%, and duration of the impulse less than 0.3 seconds.

举例：当每小时运转次数=1800 次，加速和减速占时各为0.1 秒，(0.1<0.3 秒，3600/1800=2 秒，因此，加/减速在每转次的占时比例为0.1+0.1秒)/2 秒 = 10%，因此，按照图表所得加/减速扭矩因数 = 1.75；此时考虑综合因数，结合到1800 次时的额定输出扭矩因数 = 0.8 x 1.75= 1.4，因此所得最高加/减速扭矩= 额定输出扭矩x 1.4。 假设加/减速耗时大于0.3 秒，那么加/减速扭矩必须≤额定输出扭矩。

Example: If numbers of cycles per hour are 1800times, acceleration time 0.1 seconds, deceleration time 0.1 seconds (0.1<0.3, also 3600/1800 = 2 seconds, therefore, percentage of acceleration & deceleration time in one cycle time is (0.1+0.1)/2=10%), then max. acceleration/deceleration torque is 1.4 times (0.8X1.75=1.4) of each XP(XF) model rated output torque. If acceleration & deceleration time is over 0.3 seconds, then acceleration /deceleration torque should not exceed its rated output torque.

CP
XP
MM
SS
XQ

Xcellent - Planetary 订购须知 Xcellent - Planetary **Ordering Information**

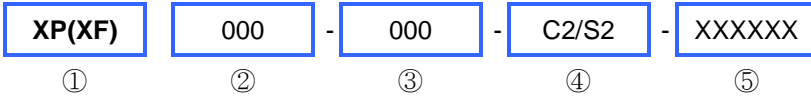

- ① 系列 **Model name** : XP(法兰输出型/Output flange output), XF(箱体输出型/Case output)
 XP(XF): 标准级Standard, XP⁺(XF⁺): 精密级Reduced, XP⁺⁺(XF⁺⁺): 特选级Selected, XP²(XF²): 高精级Advanced
- ② 型号 **Model Number**:
- ③ 速比 **Ratio**:

品名Model name	1级 1 stage	2级 2 stage	品名Model name	1级1 stage	2级 2 stage
XP07A	4, 5, 7, 10	16,20,25,28,35,49,70,100	XP045	4, 5, 7, 10	16, 21, 31, 43, 61, (64), 91
XP015	4, 5, 7, 10	16,21,31,43,61,(64),91	XP090	4, 5, 7, 10	16, 21, 31, 43, 61, (64), 91

XF 系列的速比 = (XP 1级的速比 - 1) XF series ratio is 'XP 1 stage ratio-1'.

- ④ 输入方式 **Input style**: C2-夹套输入型 Clamp input, S2-轴输入型 Shaft input
- ⑤ **XP(XF) 电机代码 XP(XF) motor code**: 请看下示表格 See below table

XP: S2输入形式, 此项留空; XP(XF): C2输入形式, 不带法兰请注明'NF'. Blank for XP S2 type input, 'NF' for C2 type input w/o motor flange.
 XF系列的S2输入应用请联系我司。Please contact SEJINIGB for XF S2 input style application.

XP(XF) 系列应用的电机代码 XP(XF) series Applied Motor Code

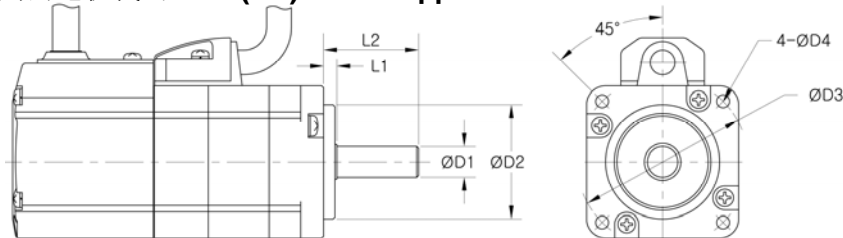

XP(XF) 系列 Model			尺寸 Dimensions		L1 最大 (Max)	L2		D1	D2	D3	D4
1级 Stage	2级 Stage	电机代码 Motor Code	最小 Min	最大 Max							
XP(F)07A	XP015	A040PP	20	28	4.0	20	28	8	30	45	3.5(M3)
XP(F)07A	XP015	A040PM	20	28	4.0	20	28	8	30	46	4.5(M4)
{XP(F)07A}	{XP015}	A040PF	22	28	7.0	22	28	8	30	46	4.5(M4)
XP(F)015, XP(F)07A	XP015	A060PQ	20	28	5.0	20	28	8	50	70	4.5(M4)
XP(F)015, XP(F)07A	XP015	A060PU	20	28	5.0	20	28	8	50	70	5.5(M5)
XP(F)015, XP(F)07A	XP015, XP045	A060P2	20	30	5.0	20	30	11	50	70	4.5(M4)
XP(F)015, XP(F)07A	XP015, XP045	A060PP	20	30	5.0	20	30	14	50	70	4.5(M4)
XP(F)015, XP(F)07A	XP015, XP045	A060PM	20	30	5.0	20	30	14	50	70	5.5(M5)
{XF07A, XF015}, XP(F)045	{XP015}	A080P2	27	30	9.0	27	30	11	70	90	5.5(M5)
{XF07A, XF015}, XP(F)045	{XP015}, XP045	A080PQ	27	30	9.0	27	30	14	70	90	5.5(M5)
{XF07A, XF015}, XP(F)045	{XP015}, XP045	A080PU	27	30	9.0	27	30	14	70	90	6.6(M6)
XP(F)045	XP045, XP090	A080PY	30	40	9.0	30	40	16	70	90	6.6(M6)
XP(F)045	XP045, XP090	A080PP	30	40	9.0	30	40	19	70	90	5.5(M5)
XP(F)045	XP045, XP090	A080PM	30	40	9.0	30	40	19	70	90	6.6(M6)
{XP(F)045}	XP090	A090PP	40	55	9.0	40	55	19	80	100	6.6(M6)
XF045, XP(F)090	{XP045}, XP090	A100PG	30	40	9.0	30	40	16	95	115	9(M8)
{XF045}, XP(F)090	XP090	A100PP	40	55	9.0	40	55	19	95	115	9(M8)
XP(F)090	XP090	A100PM	40	58	9.0	40	58	24	95	115	9(M8)
XP(F)090	XP090	A120PY	40	58	9.0	40	58	16	110	145	9(M8)
XP(F)090	XP090	A120PS	40	58	9.0	40	58	19	110	145	9(M8)
XP(F)090	XP090	A120PP	40	58	9.0	40	58	22	110	145	9(M8)
XF090	-	A130PM	40	58	9.0	40	58	24	110	145	9(M8)
XF090	{XP090}	A130PP	40	58	9.0	40	58	22	110	145	9(M8)
XF090	{XP090}	A130PY	40	58	9.0	40	58	19	110	145	9(M8)

 上示电机尺寸仅考虑安装所需的最小尺寸, 并不代表实际对电机所需的扭矩范围。Listed motor and XP(XF) combinations are only consider mechanical dimensions with smallest XP(XF), not actual available torque range.

 在不同的应用下, 电机与法兰尺寸可能需要安装前灵活考虑, 比如: 附加适配座等辅助件。{}表示可选电机法兰尺寸。Installable motor size may be varied by installing conditions, such as additional adaptor. {} shows optional motor flange combinations.

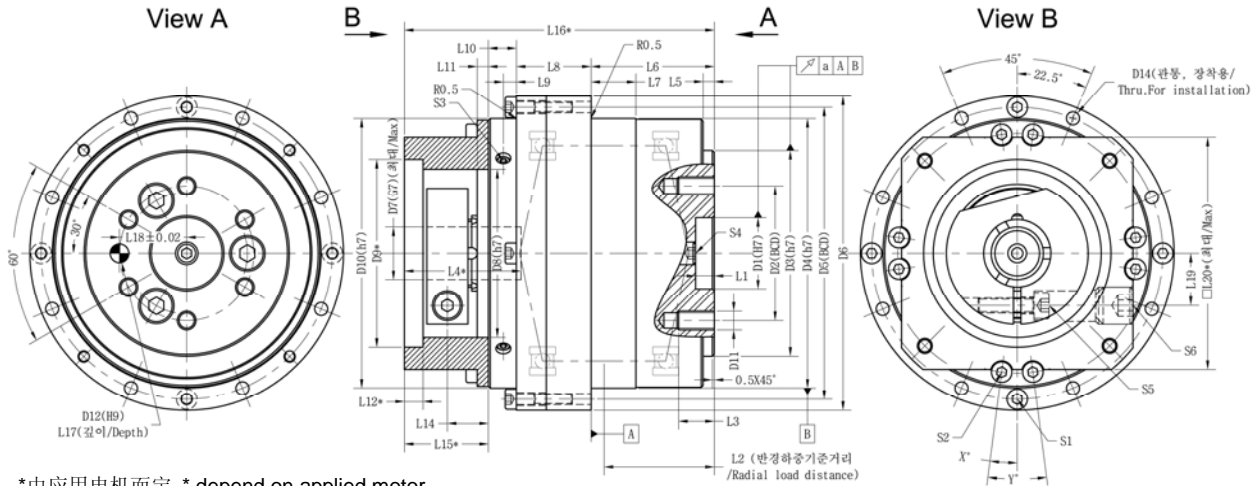

*由应用电机而定 * depend on applied motor.

XP (1级 C2型 输入方式) 尺寸表 XP (1 stage C2 input style) Dimensions (mm)

符号 Symbol	尺寸 Size	XP07A	XP015	XP045	XP090	XP180
a		0.03	0.03	0.03	0.03	0.03
D1 (H7)		12	19	28	40	50
D2 (B.C.D)		28	36	60	80	90
D3 (h7)		42	55	75	105	125
D4 (h7)		57	72	100	130	163
D5 (B.C.D)		63	78	109	140	176
D6		69	84	118	150	188
D7 (G7)		11 [14]	14	19 [22]	24 [28]	35
D8 (h7)		44(H7)	45	63	90	105
D9 *		30.2 [50.2]	50.2	70.2 [80.2]	110.2 [110.2]	114.4
D10 (h7)		56	72	100	130	164
D11		6XM4	6XM5	6XM6	6XM8	6XM10
D12 (H9)		4	5	6	8	10
D14		8X3.5	8X3.5	8X4.5	8X5.5	8X6.6
L1		5	5	8	7	12
L2		24.75	29.5	37	45.25	58.5
L3		7	9	11	15	20
L4 *		28 [30]	30	40 [58]	58 [58]	80
L5		3	3	3.5	3.5	4.5
L6		29	33	40.5	52.5	63
L7		12	12	17	21	24.5
L8		15.5	20	28	37	44
L9		-	3.5	4.5	4	5.5
L10		7	7.5	9	8	11
L11		(-4)	3	3	3	3
L12 *		4 [5]	5	9 [11]	9.5 [9.5]	25
L14		7	11	11.5	17	23
L15 *		17.5 [18.5]	22.5	29.5 [46.5]	36.5 [58]	65
L16 *		69 [70]	83	107 [124]	134 [134]	183
L17		4	5	6	8	10
L18 ±0.02		14	18	30	40	45
L19		11 [12]	14	19 [19]	21 [21]	32
L20 *		40 [60]	60	80 [90]	120 [120]	180
S1		4XM3	4XM3	4XM4	4XM5	4XM6
S2		8XM2.5 (B.C.D50)	8XM3 (B.C.D64)	8XM4 (B.C.D90)	12XM4 (B.C.D101)	8XM5 (B.C.D145)
S3 (止动螺丝 Set screw)		-	2XM4	2XM4	2XM4	2XM6
S4 (止动螺丝 Set screw)		M6	M6	M6	M8	M8
S5		M4	M5	M6	M8	M10
S6 (止动螺丝 Set screw)		M6 [M8]	M10	M12	M14	M16
X°		7.5°	7.5°	10°	0°	0°
Y°		15°	15°	20°	30° (等距/Isometric)	30° (等距/Isometric)

CP
XP
MM
SS
XQ

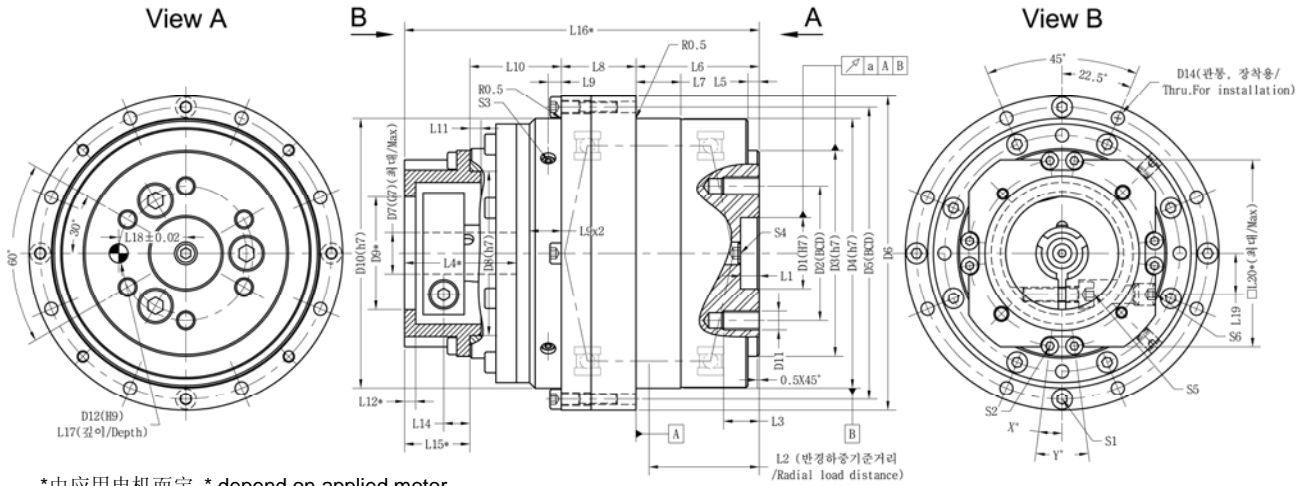

*由应用电机而定 * depend on applied motor.

XP (2级 C2型 输入方式) 尺寸表 XP (2 stage C2 input style) Dimensions (mm)

符号 Symbol	尺寸 Size	XP07A	XP015	XP045	XP090
a		0.03	0.03	0.03	0.03
D1 (H7)		12	19	28	40
D2 (B.C.D)		28	36	60	80
D3 (h7)		42	55	75	105
D4 (h7)		57	72	100	130
D5 (B.C.D)		63	78	109	140
D6		69	84	118	150
D7 (G7)		11 [14]	11 [14]	14 [19]	19 [22]
D8 (h7)		37	44(H7)	45	63
D9 *		30.2	30.2 [50.2]	50.2 [70.2]	70.2 [110.2]
D10 (h7)		56	72	100	130
D11		6XM4	6XM5	6XM6	6XM8
D12 (H9)		4	5	6	8
D14		8X3.5	8X3.5	8X4.5	8X5.5
L1		5	5	8	7
L2		24.75	29.5	37	45.25
L3		7	9	11	15
L4 *		28 [30]	28 [30]	30 [40]	40 [58]
L5		3	3	3.5	3.5
L6		29	33	40.5	52.5
L7		12	12	17	21
L8		15.5	20	28	37
L9		-(L9X2=8.5)	3.5 (L9X2=8.5)	23.5 (L9X2=13.5)	25 (L9X2=9)
L10		28	24.5	29	28
L11		4.5 [5]	(-)4	3	3
L12 *		4 [5]	4 [5]	5 [12]	9 [14]
L14		17	7	11	11.5
L15 *		27.5 [28.5]	17.5 [18.5]	22.5 [33]	29.5 [46.5]
L16 *		100 [101]	95 [96]	120 [130.5]	147 [164]
L17		4	5	6	8
L18 ±0.02		14	18	30	40
L19		11 [12]	11 [12]	14 [17]	19
L20 *		40 [60]	40 [60]	60 [80]	80 [120]
S1		4XM3	4XM3	4XM4	4XM5
S2		8XM3 (B.C.D45)	8XM2.5 (B.C.D50)	8XM3 (B.C.D64)	8XM4 (B.C.D90)
S3 (止动螺丝 Set screw)		-	2XM4	2XM4	2XM4
S4 (止动螺丝 Set screw)		M6	M6	M6	M8
S5		M4	M4	M5	M6
S6 (止动螺丝 Set screw)		M6 [M8]	M6 [M8]	M10	M12
X°		22.5°	7.5°	7.5°	10°
Y°		45°	15°	15°	20°

CP

XP

MM

SS

XQ

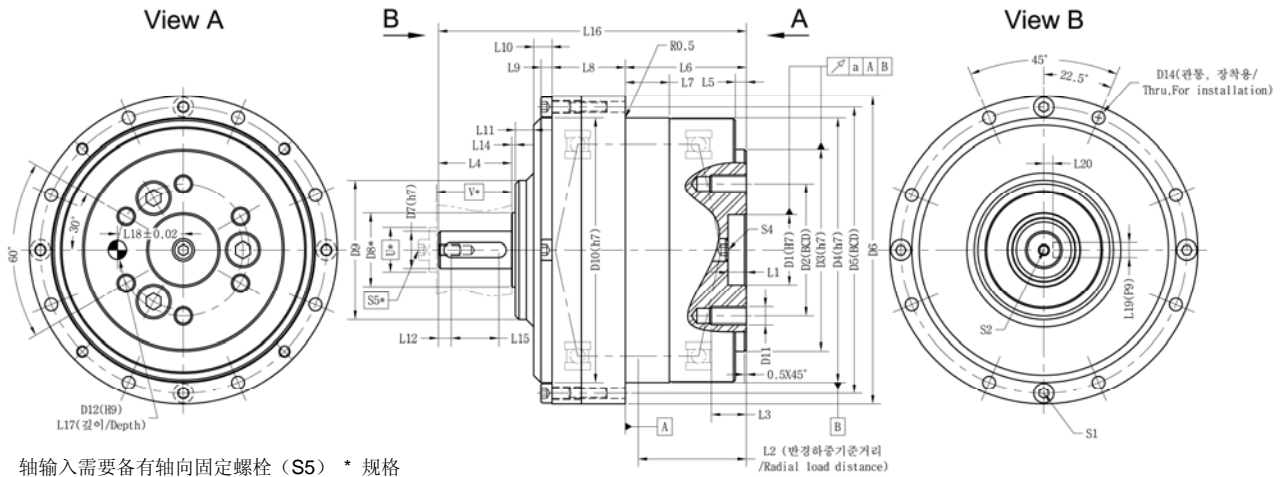

轴输入需要具备有轴向固定螺栓 (S5) * 规格
Input shaft must have axial fixing bolt (S5) with * dimensions.

XP (1级 S2型 输入方式) 尺寸表 XP(1 stage S2 input style) Dimensions (mm)

符号 Symbol	尺寸 Size	XP07A	XP015	XP045	XP090
a		0.03	0.03	0.03	0.03
D1	(H7)	12	19	28	40
D2	(B.C.D)	28	36	60	80
D3	(h7)	42	55	75	105
D4	(h7)	57	72	100	130
D5	(B.C.D)	63	78	109	140
D6		69	84	118	150
D7	(h7)	8	10	16	19
D8	*(最小/Min)	15	20	30	36
D9		30	38	54	66
D10	(h7)	56	72	100	130
D11		6XM4	6XM5	6XM6	6XM8
D12	(H9)	4	5	6	8
D14		8X3.5	8X3.5	8X4.5	8X5.5
L1		5	5	8	7
L2		24.75	29.5	37	45.25
L3		7	9	11	15
L4		16	20	30	38
L5		3	3	3.5	3.5
L6		29	33	40.5	52.5
L7		12	12	17	21
L8		15.5	20	28	37
L9		2.5	3	4.5	4
L10		3.5	5	8.5	6
L11		8	5	11	9
L12		3	3.5	5	6
L14		1	1	1	1
L15		10	13	19	26
L16		73	84	119	143.5
L17		4	5	6	8
L18	±0.02	14	18	30	40
L19	(P9)	3	4	5	6
L20		2.2	2.5	5	6
S1		4XM3	4XM3	4XM4	4XM5
S2		M2.5 (深度/Depth 4)	M3 (深度/Depth 5)	M6 (深度/Depth 11)	M6 (深度/Depth 11)
S3		-	-	-	-
S4	(止动螺丝 Set screw)	M6	M6	M6	M8
S5	*	M2.5	M3	M6	M6
S6		-	-	-	-
U	*(最小/Min)	12	14	20	23
V	*(最小/Min)	16.5	20.5	30.5	38.5

CP
XP
MM
SS
XQ

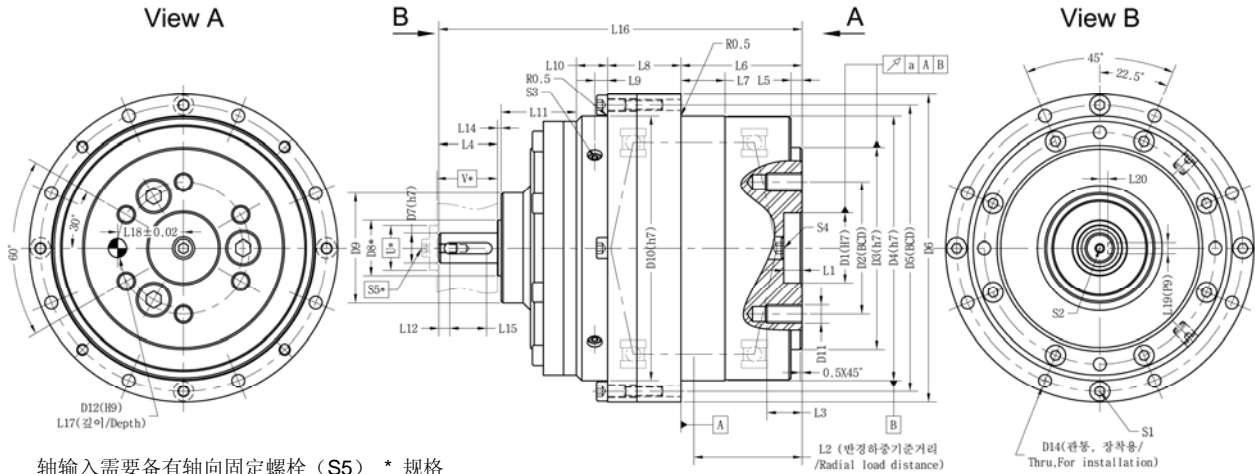

轴输入需要备有轴向固定螺栓 (S5) * 规格
Input shaft must have axial fixing bolt (S5) with * dimensions.

XP (2级 S2型 输入方式) 尺寸表 **XP (2 stage S2 input style) Dimensions (mm)**

符号 Symbol	尺寸 Size	XP07A	XP015	XP045	XP090
a		0.03	0.03	0.03	0.03
D1 (H7)		12	19	28	40
D2 (B.C.D)		28	36	60	80
D3 (h7)		42	55	75	105
D4 (h7)		57	72	100	130
D5 (B.C.D)		63	78	109	140
D6		69	84	118	150
D7 (h7)		8	8	10	16
D8 *(最小/Min)		15	15	20	30
D9		32	30	38	54
D10 (h7)		56	72	100	130
D11		6XM4	6XM5	6XM6	6XM8
D12 (H9)		4	5	6	8
D14		8X3.5	8X3.5	8X4.5	8X5.5
L1		5	5	8	7
L2		24.75	29.5	37	45.25
L3		7	9	11	15
L4		16	16	20	30
L5		3	3	3.5	3.5
L6		29	33	40.5	52.5
L7		12	12	17	21
L8		15.5	20	28	37
L9		-	3.5	-	-
L10		9	8.5	13.5	9
L11		29.5	20.5	18	29.5
L12		3	3	3.5	5
L14		1	1	1	1
L15		10	10	13	19
L16		100	99	121	159
L17		4	5	6	8
L18 ±0.02		14	18	30	40
L19 (P9)		3	3	4	5
L20		2.2	2.2	2.5	5
S1		4XM3	4XM3	4XM4	4XM5
S2		M2.5 (深度/Depth 4)	M2.5 (深度/Depth 4)	M3 (深度/Depth 5)	M6 (深度/Depth 11)
S3		-	M4	-	-
S4 (止动螺丝 Set screw)		M6	M6	M6	M8
S5 *		M2.5	M2.5	M3	M6
S6		-	-	-	-
U *(最小/Min)		12	12	14	20
V *(最小/Min)		16.5	16.5	20.5	30.5

CP

XP

MM

SS

XQ

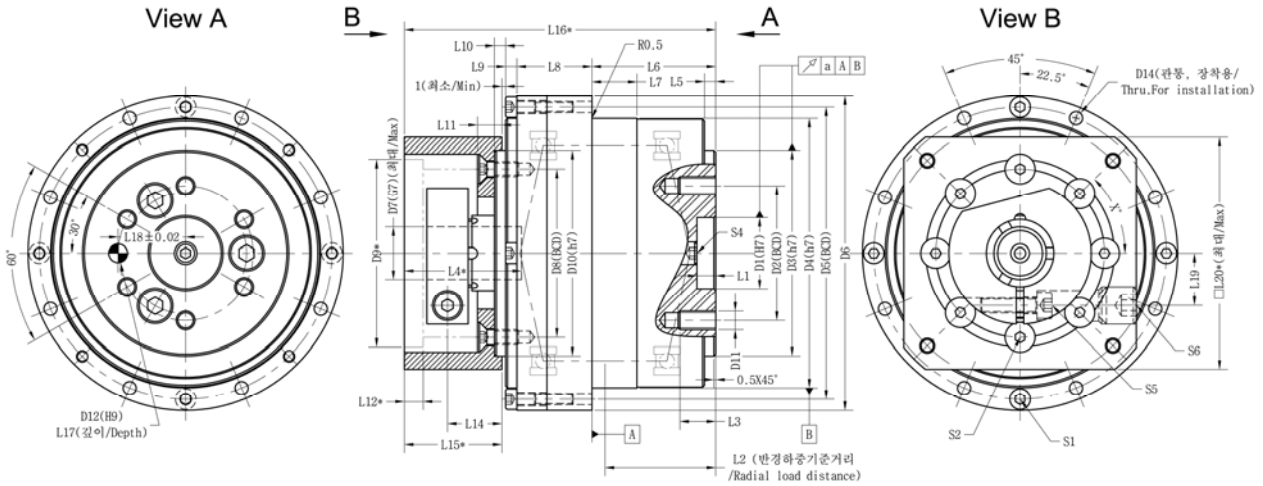

*由应用电机而定。 * depend on applied motor.

XF (1级 C2型 输入方式) 尺寸表 **XF (1 stage C2 input style) Dimensions (mm)**

符号 Symbol	尺寸 Size	XF07A	XF015	XF045	XF090
a		0.03	0.03	0.03	0.03
D1	(H7)	12	19	28	40
D2	(B.C.D)	28	36	60	80
D3	(h7)	42	55	75	105
D4	(h7)	57	72	100	130
D5	(B.C.D)	63	78	109	140
D6		69	84	118	150
D7	(G7) (最大/Max)	11 [14]	14	19 [22]	24 [28]
D8	(B.C.D)	35	45	64.5	80
D9	*	30.2 [50.2]	50.2	70.2	110.2
D10	(h7)	42	55	75	105
D11		6XM4	6XM5	6XM6	6XM8
D12	(H9)	4	5	6	8
D14		8X3.5	8X3.5	8X4.5	8X5.5
L1		5	5	8	7
L2		24.75	29.5	37	45.25
L3		7	9	11	15
L4	*	28 [30]	30	40	60
L5		3	3	3.5	3.5
L6		29	33	40.5	52.5
L7		12	12	17	21
L8		15.5	20	28	34.5
L9		2	3	2	0
L10		2.5	3	4	4
L11		3	6.5	8	8
L12	*	4 [5]	5	10	9
L14		11	14.5	17.5	26.5
L15	*	21.5 [22.5]	26	35.5	46
L16		69 [70]	83	107	134
L17		4	5	6	8
L18	±0.02	14	18	30	40
L19		11 [12]	14	19	21
L20	*(最大/Max)	40 [60]	60	80	120
S1		4XM3	4XM3	4XM4	4XM5
S2		8XM3 (平头Flat head)	8XM4 (平头Flat head)	8XM4	12XM4
S3		-	-	-	-
S4	(止动螺丝Set screw)	M6	M6	M6	M8
S5		M4	M5	M6	M8
S6	(止动螺丝Set screw)	M6 [M8]	M10	M12	M14
X°		45°	45°	45°	30°
Y°		-	-	-	-

CP
XP
MM
SS
XQ

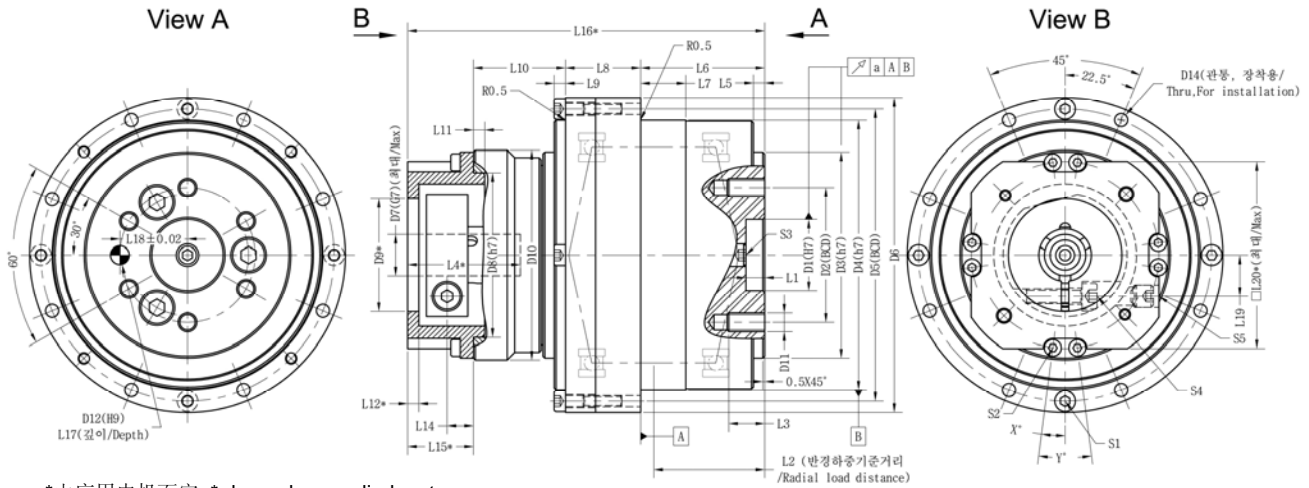

*由应用电机而定. * depend on applied motor.

XF (2级 C2 输入方式) 尺寸表 XF (2 stage C2 input style) Dimensions (mm)

Symbol	Size	XF07A	XF015	XF045	XF090
a			0.03	0.03	0.03
D1	(H7)		19	28	40
D2	(B.C.D)		36	60	80
D3	(h7)		55	75	105
D4	(h7)		72	100	130
D5	(B.C.D)		78	109	140
D6			84	118	150
D7	(G7) (最大/Max)		11 [14]	14 [19]	19 [22]
D8	(h7)		44(H7)	45	63
D9	*		30.2 [50.2]	50.2 [70.2]	70.2 [110.2]
D10			56	72	100
D11			6XM5	6XM6	6XM8
D12	(H9)		5	6	8
D14			8X3.5	8X4.5	8X5.5
L1			5	8	7
L2			29.5	37	45.25
L3			9	11	15
L4	*		28 [30]	30 [40]	40 [58]
L5			3	3.5	3.5
L6			33	40.5	52.5
L7			12	17	21
L8			20	28	34.5
L9			3	2	-
L10			24.5	29	30.5
L11			(-)-4	3	3
L12	*		4 [5]	5 [12]	9 [14]
L14			7	11	11.5
L15	*		17.5 [18.5]	22.5 [33]	29.5 [46.5]
L16			95 [96]	120 [130.5]	147 [164]
L17			5	6	8
L18	±0.02		18	30	40
L19			11 [12]	14 [17]	19
L20	*(最大/Max)		80	120	150
S1			4XM3	4XM4	4XM5
S2			8XM2.5 (B.C.D50)	8XM3 (B.C.D64)	8XM4 (B.C.D90)
S3	(止动螺丝 Set screw)		M6	M6	M8
S4			M5	M6	M8
S5	(止动螺丝 Set screw)		M10	M12	M14
X°			7.5°	7.5°	108
Y°			15°	15°	20°

请与赛劲联系
Please contact SEJINIGB.

CP

XP

MM

SS

XQ

Xcellent Planetary

View A

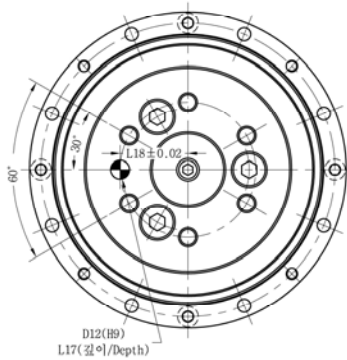

be precise with

View B

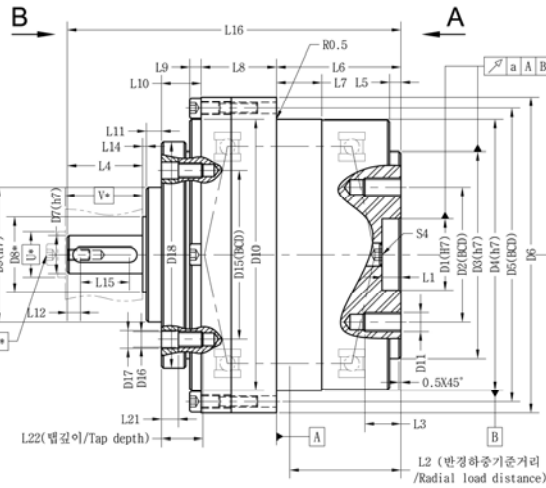
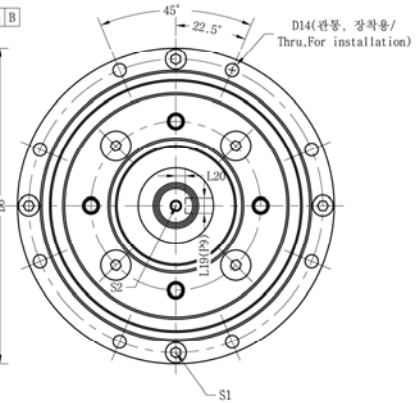

XF (1级 S2 输入方式) 尺寸表 XF (1 stage S2 input style) Dimensions (mm)

Symbol	Size	XF07A	XF015	XF045	XF090
a		0.03	0.03	0.03	0.03
D1 (H7)		12	19	28	40
D2 (B.C.D)		28	36	60	80
D3 (h7)		42	55	75	105
D4 (h7)		57	72	100	130
D5 (B.C.D)		63	78	109	140
D6		69	84	118	150
D7 (h7)		8	10	16	19
D8 *(最小/Min)		15	20	30	36
D9 (h7)		29	36	54	66
D10		56	72	100	-
D11		6XM4	6XM5	6XM6	6XM8
D12 (H9)		4	5	6	8
D14		8X3.5	8X3.5	8X4.5	8X5.5
D15 (B.C.D)		35.5	45	64.5	80
D16		4XM3	4XM4	4XM4	4XM4
D17		4X3.5	4X4.5	4X4.5	4X4.5
D18		45	60	85	110
L1		5	5	8	7
L2		24.75	29.5	37	45.25
L3		7	9	11	15
L4		16	20	30	38
L5		3	3	3.5	3.5
L6		29	33	40.5	52.5
L7		12	12	17	21
L8		15.5	20	28	34.5
L9		2	3	2	-
L10		7.5	10.5	10	8.5
L11		4	4	9.5	9
L12		3	3.5	5	6
L14		1	1	1	1
L15		10	13	19	26
L16		73	88.5	119	143.5
L17		4	5	6	8
L18 ±0.02		14	18	30	40
L19 (P9)		3	4	5	6
L20		2.2	2.5	5	6
L21		3	4	4	4.5
L22		8.5	10.5	12	12
S1		4XM3	4XM3	4XM4	4XM5
S2		M2.5 (深度/Depth 4)	M3 (深度/Depth 5)	M6 (深度/Depth 11)	M6 (深度/Depth 11)
S4 (止动螺丝/Set screw)		M6	M6	M6	M8
S5 *		M2.5	M3	M6	M6
U *(最小/Min)		12	14	20	23
V *(最小/Min)		16.5	20.5	30.5	38.5

CP
XP
MM
SS
XQ

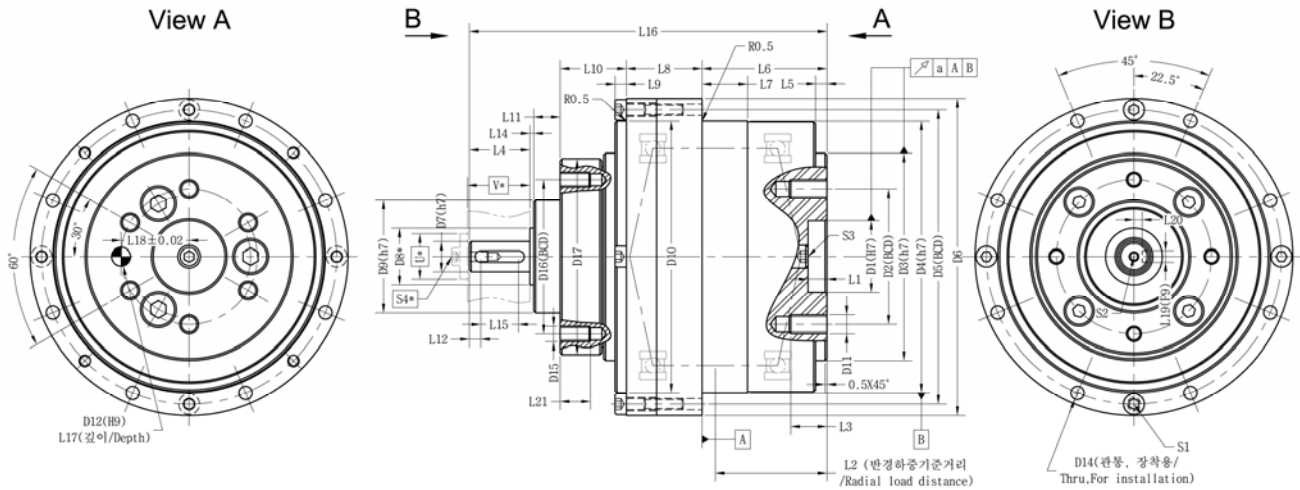

XF (2级 S2 输入方式) 尺寸表 XF (2 stage S2 input style) Dimensions (mm)

Symbol	Size	XF07A	XF015	XF045	XF090
a			0.03	0.03	0.03
D1	(H7)		19	28	40
D2	(B.C.D)		36	60	80
D3	(h7)		55	75	105
D4	(h7)		72	100	130
D5	(B.C.D)		78	109	140
D6			84	118	150
D7	(h7)		8	10	16
D8	*(最小/Min)		15	20	30
D9	(h7)		30	40	60
D10			72	100	-
D11			6XM5	6XM6	6XM8
D12	(H9)		5	6	8
D14			8X3.5	8X4.5	8X5.5
D15			4XM4	4XM5	8XM5
D16	(B.C.D)		41	55.5	73
D17			52	67	86
L1			5	8	7
L2			29.5	37	45.25
L3			9	11	15
L4		请与赛劲联系	16	20	30
L5			3	3.5	3.5
L6		Please contact SEJINIGB.	33	40.5	52.5
L7			12	17	21
L8			20	28	34.5
L9			3	2	-
L10			17.5	22.5	17
L11			7	9	24
L12			3	3.5	5
L14			1	1	1
L15			10	13	19
L16			94.5	121	159
L17			5	6	8
L18	±0.02		18	30	40
L19	(P9)		3	4	5
L20			2.2	2.5	5
L21			7.5	9.5	9.5
S1			4XM3	4XM4	4XM5
S2			M2.5 (深度/Depth 4)	M3 (深度/Depth 5)	M6 (深度/Depth 11)
S3	(止动螺丝 Set screw)		M6	M6	M8
S4	*		M2.5	M3	M6
U	*(最小/Min)		12	14	20
V	*(最小/Min)		16.5	20.5	30.5

CP

XP

MM

SS

XQ

XP(XF) 安装指导 XP(XF) series Assembly Instructions

注意General: 遵循以下安装指导可以快速有效的把电机与齿轮箱配合得坚实，同时摆脱安装后的间隙。

A torsionally rigid and backlash free connection between motor and XP(XF) can quickly and easily be achieved by using the following assembly instructions.

Note 注: 请仅应有带安装法兰并表面跳动精度符合 **DIN 4 2 9 5 5 N** 或 **DIN 4 2 9 5 5 R** 标准的电机。
Please only use motors with a flange face and run out accuracy class DIN 42955 N or DIN 42955 R.

为避免转动系安装的中心位移问题，XP(XF) 输入端应用了‘开放式同心自动校正’设计以规避了传统中心位移问题。首先，把齿轮箱倒立置放在桌面上，电机输出轴从上往下植入齿轮箱输入联轴节内⑥，拧紧夹套⑤上的拉紧螺丝⑦，最后把将电机与齿轮箱固定⑧。

To avoid misalignment inside the power train, the standard XP(XF) utilizes our new “open centering” design making the laborious task of centering with the flange and pilot obsolete. Place XP(XF) upside down, simply insert the motor shaft into the gearbox hollow shaft ⑥, tightens the clamping bolt ⑦ on the compression coupling ⑤, and attaches the gearbox to the motor using the mounting holes.

XP(XF)系列 齿轮箱不需要周期维护，并且属于永久性润滑型。

The XP(XF) series are maintenance free and have a lifetime lubrication.

电机安装顺序 Motor Mounting Instructions:

- 如果电机上自带输出轴平键②，请取出弃用；在实际使用转速高于3000rpm的情况下，我方建议把电机轴径上的键槽用同等材质堵上，比如改装该平键（填平后不能突出弧面），以避免偏心震动。If the motor shaft has a key ②, remove it. For applications with motor speeds over 3000 rpm, we recommend using a half key to completely fill the key way. The key may not stand out above the height of the motor shaft.
- 把电机法兰④里的（堵孔用）止动螺丝③取出。Remove set screw ③ on the adapter flange ④, put it aside, reserving it for later use.
- 旋转夹套⑤，直到拉紧螺丝⑦的头部对准扳手让位孔③。Turn the compression coupling ⑤ until the head of the clamping bolt ⑦ is visible through the access hole ③.
- 检查电机法兰和安装法兰④以确保表面干净，同时也务必检查电机输出轴②和齿轮箱夹套输入端口⑥，确定表面没有毛刺或铁屑等阻碍物。Examine all contact surfaces on the motor flange and the adapter flange ④ to ensure they are clean and grease free. Also inspect the motor shaft and the hub to ensure they are free from damage (burrs, scoring, etc.).
- 把齿轮箱以输入端口向上的方式平放在桌面上，确定电机输出轴键槽部分180°背对夹套的切缝。Place XP(XF) upside down (input side upward) and secure it from falling. Ensure that the key way in the motor shaft (if there is) is positioned opposite the slit (180°) in the compression coupling when assembled.
- 如果输入端必须使用变径轴套的话，确定变径轴套的切缝与减速箱夹套⑤的切缝保持在相同方向，呈直线。If a reduction bushing is used, ensure the slit in the bushing is aligned with the compression coupling ⑤ slit.
- 把电机输出轴轻轻放入减速箱输入端口⑥直至电机法兰平面与减速箱法兰面相接合。切勿使劲将输出轴压入输入端口。假设减速箱或电机过重，请参考使用轻型起重机。
If the XP(XF) is too heavy to lift manually, a suitable hoisting machine should be used. Insert the motor shaft into XP(XF) hollow shaft ⑥, until the motor flange naturally mates with the adapter flange over its entire surface. Do not strike the XP(XF) or use excessive force to ensure a good fit.
- 把夹套螺丝⑦拉紧（关于夹套螺丝的拉紧扭矩请参考以上螺丝拉紧扭矩表），务必使用恰当的工具，比如扭矩扳手⑨。
Tighten the clamping bolt ⑦ to the prescribed torque (see table tightening torque) using a suitable torque wrench ⑨.
- 接着以对角顺序的方式用螺丝将电机①与减速箱⑧固定。Now bolt XP(XF) and motor ① together using the mounting holes ⑧ in the adapter flange. The bolts must be diagonally transferred and uniformly tightened.
- 最后把（堵孔用）止动螺丝③（看步骤-2）拧入齿轮箱法兰④。
Tightening access hole set screw ③ into adapter flange ④.

Note 注: 违反或忽视以上安装步骤可能会给电机或齿轮箱造成损坏，并且将会违反质保条件。Failure to follow assembly instructions may lead to gearbox and/or motor damage and will void any warranty either explicit or implied.

螺丝拉紧扭矩表 ⑦	
Tightening torque for clamping bolt ⑦	
螺丝规格Clamping Screw (DIN 912)	拉紧扭矩 Tightening torque
M4	4.5Nm
M5	9Nm
M6	16Nm
M8	39Nm

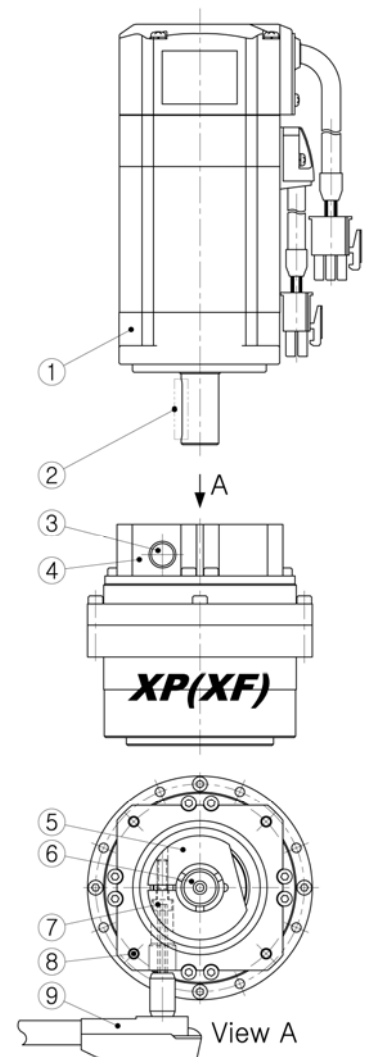

CP

XP

MM

SS

XQ

XP (S2 输入方式) 输入端轴承承载表 **XP (S2 input style) Input Bearing capacity**

综合载荷 Combined (@n _{in} =2000rpm)		XP07A	XP015	XP045	XP090
最高径向负载 Max. radial load	1级(stage)	165N	250N	730N	910N
	2级(stage)	165N	165N	250N	730N
最高轴向负载 Max. axial load	1级(stage)	165N	250N	730N	910N
	2级(stage)	165N	165N	250N	730N

XP(XF) 安装与应用例举 **XP(XF) Installation & Application examples**

XP-C2 带轮/驱动轮
XP-C2 as pulley/wheel drive

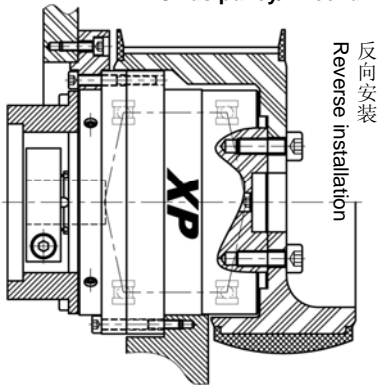

XF-C2 带轮/驱动轮
XF-C2 as pulley/wheel drive

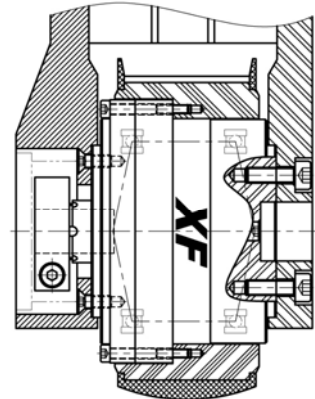
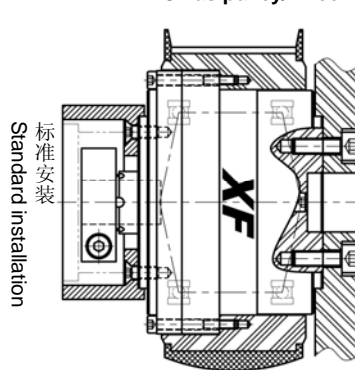

XF-C2 带轮/驱动轮；两端固定式
XF-C2 as pulley/wheel drive with both end support

XP-C2 反向安装的齿条-齿轮传动
XP-C2 reverse installation as Rack-Pinion drive

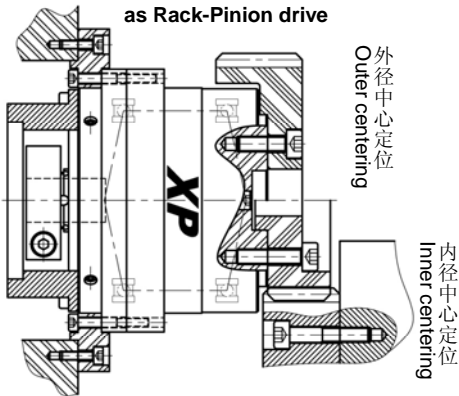

XP-C2 标准安装的齿条-齿轮传动
XP-C2 standard installation as Rack-Pinion drive

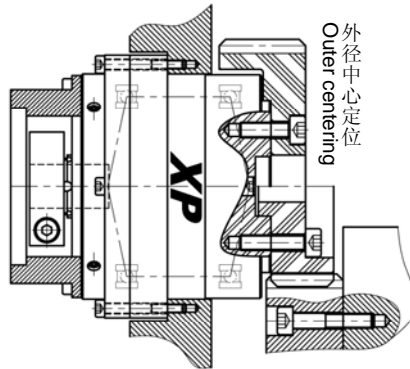

XF-C2 齿条-齿轮传动
XF-C2 as Rack-Pinion drive

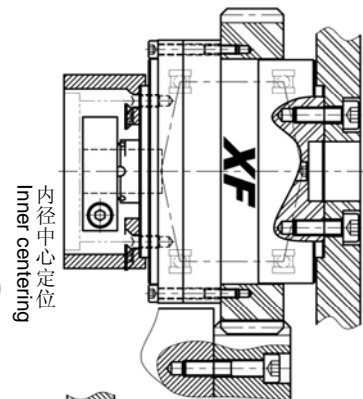

XP-C2 转台的应用
XP-C2 as turn-table

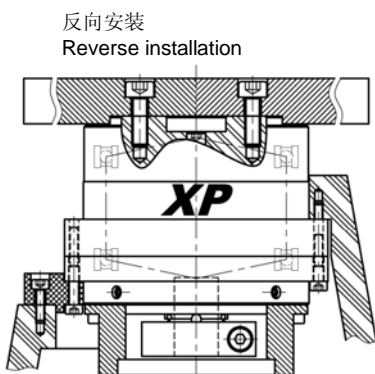

XF-C2 转台的应用
XF-C2 as turn-table

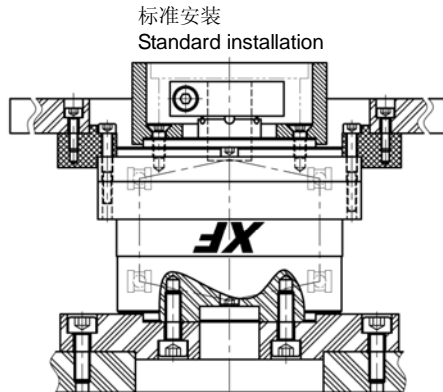

XP-S2 差动模式
XP-S2 as differential

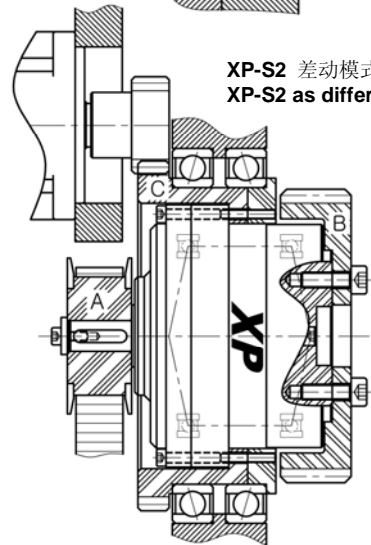

CP

XP

MM

SS

XQ